



# Grinder Guard & Grit-Grabber

## Grinder and Buffer Shield and Dust Collection System

The Grinder Guard™ is designed to fit ALL pedestal and bench grinders, which translates into maximum versatility and long shop life. Reduce liability exposure and increase worker safety protection with Midaco's Grinder Guard™

*Turn this...*



*...into this.*

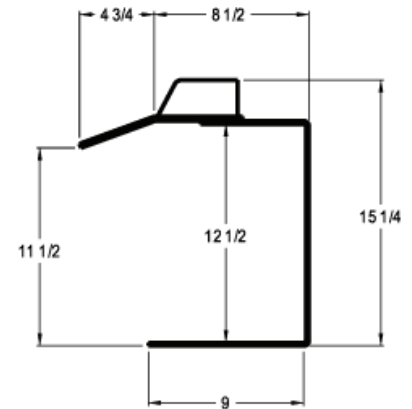
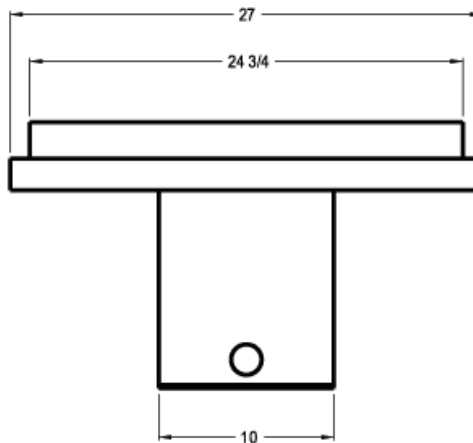

### Features

### Advantage

### Benefit

27" Full Width Visor

Protects at least 6 times more area (128 sq. inches)

Allows safety viewing from more angles

Replaceable Impact Resistant Visor

Maximum protection from sparks and dust

Stays clear longer

Full Width 24" LED Light

Increased visibility and operator comfort

Ensures greater accuracy and improves productivity

OSHA Orange

Identifies safety area

Impedes corrosion and lasts longer

# Grinder Guard & Grit-Grabber

Reduce Maintenance Costs and Improve Operator Safety with MIDACO's **GRIT-GRABBER** Dust Collection System.



The easily replaced or cleaned collection filter is made up of 3 grades of treated, flame retardant filter material to offer maximum performance and reduction in the amount of dust and grit discharged into the work area. An aluminum mesh screen "spark arrester" is included and sits on top of the filter.

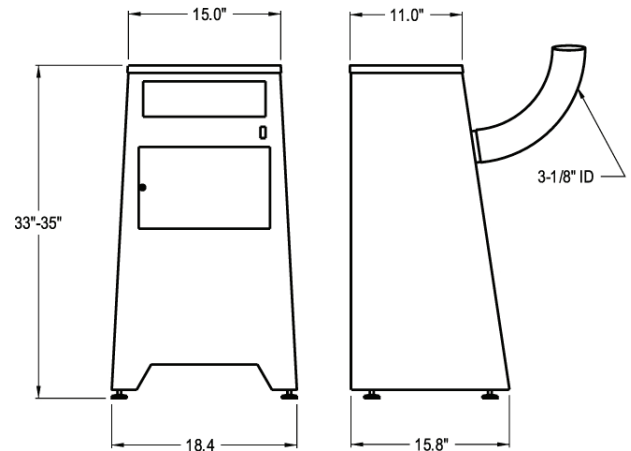

## Grit Grabber Dust Collector

Features	Advantage	Benefit
<b>Heavy Duty Motor</b>	Sealed bearing industrial motor offers long term service	Minimizes downtime and maintenance costs
<b>Replaceable Filter Element</b>	Easily replaced filter traps vacuumed debris	Reduces operator hazards, improves shop cleanliness
<b>Universal Hose and Clamps</b>	Durable hose, built to last, fits all models	Easy to retrofit, saves labor and time
<b>Illuminated ON-OFF Switch</b>	Red LED safety light indicates unit is on	Promotes longevity in noisy environments
<b>Compact, Vibration-Free Design</b>	Insulated enclosure operates with low noise level in 70dp (A) range	Utilizes available space and promotes safety
<b>Installation Options</b>	Self leveling feet or stationary mount	Allows multiple department or fixed position usage
<b>CFM Exhaust Level Exceeds OSHA's Minimum</b>	As specified by OSHA ventilation standard 1910.94 up to 10" diameter	Maximizes operator safety and productivity

### Performance & Durability are the Big Benefits

The Grit-Grabber and Grinder Guard are designed for the use with virtually ALL grinders and buffers. The universal design offers significant advantages in installation, operator safety, productivity and maintenance.

### Standard Size

Grit-Grabber vacuum pedestal fits 5" to 10" diameter wheels. Includes filter, hoses and clamps. 120 Volts, 60Hz (Grinders and guards are additional)

### Replacement Filters

No. GF2006 (6 per case)

### Grinder Guard

Model 46 ( up to 7" diameter, wheels)  
Model 46A (8" to 12" diameter, wheels)



**MIDACO CORPORATION**  
2000 Touhy Avenue  
Elk Grove Village, IL 60007 USA  
phone: (847) 593-8420  
fax: (847) 593-8451  
email: midaco@midaco-corp.com

**KEEP THE SPINDLE RUNNING!**

See how we fit your application  
[www.midaco-corp.com](http://www.midaco-corp.com)

