

Introducing the 16SD Automatic Pallet Changer System Series. This series is designed for Drill Tap Machines and smaller VMC's with sizes ranging from 22" x 15" to 27" x 16".

PALLET CHANGE TIME IS ONLY 6.5 SECONDS

- Load, unload, inspect parts and setup jobs while the second pallet is in the machine
- Repeatability of +/- 0.0001" (.0025mm)
- Pallet changer is fully integrated with the machine control.



Pallet Changer
shown with CE Guarding

MIDACO has decades of pallet changer experience in all areas of production. Every Midaco product is fully QC tested for 250,000 cycles before being released to market insuring that your system will operate at peak performance for years to come.

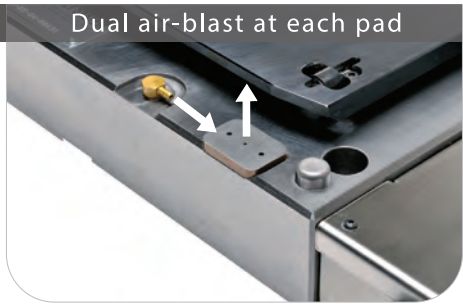
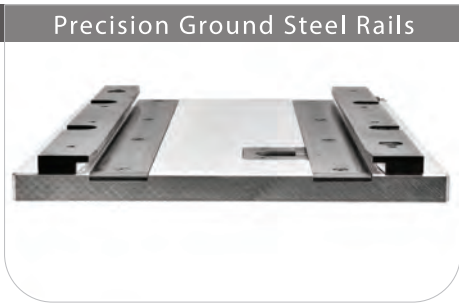
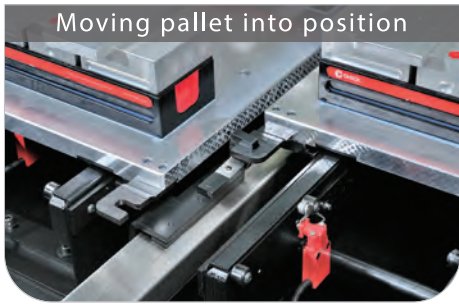
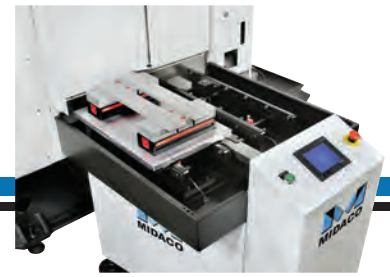

STANDARD SYSTEM INCLUDES:

- 1 - Cast Iron Receiver with Airblast for Chip Removal
- 2 - Plain Cast Aluminum Pallets
- 1 - End Mounted Shuttle
- 1 - Custom-Fitted, Automatic Door
- 1 - High-Visibility Indicator Lamp
- 1 - Pallet Clamp Confirmation

OPTIONS:

- CE Enclosure
- Pallet Transfer/Storage Accessories available



Manual Pallet System is also available

Dual Automatic System is also available on any size VMC

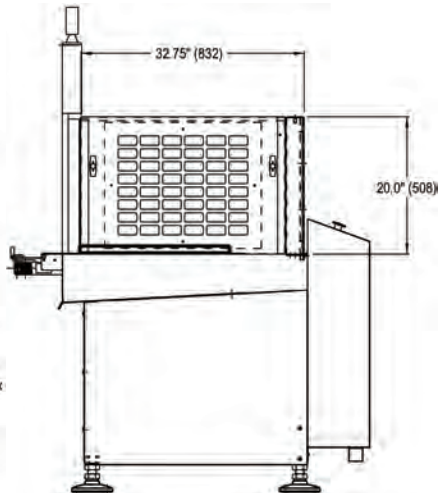
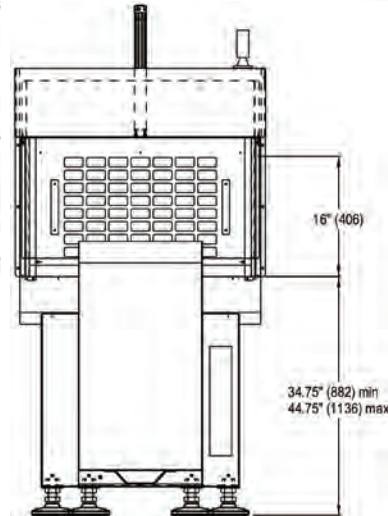
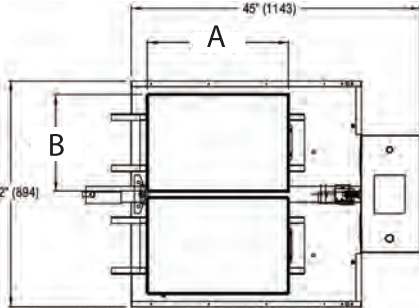
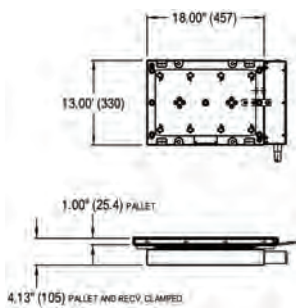

Clamping Force*	4500 lbs	(2043 kg)
Receiver Weight	95 lbs	(43 kg)
Pallet Weight	46-56 lbs	(20.7-25.2 kg)
Pallet Load Cap**	500 lbs	(225 kg)
A (Pallet "X" Dim)	22"-27"	(558.8-685.8mm)
B (Pallet "Y" Dim)	14"-15"	(355.6-381mm)

Weight capacities shown in lbs (kg) Dimensions shown in inch (mm)
 *At 100PSI (6.9 bar) **At 120PSI (8.2 bar) Patent Pending Diagram Shows optional CE Package