



# Automatic Pallet-Cart Changer for 5-Axis Machining Centers

**Work NON-STOP on 5-Axis Machining Centers.** The Automatic Pallet-Cart Changer allows for uninterrupted pallet transfer with MIDACO's train-cart system (*patent pending*). Each cart holds two (2) pallets and connects to additional carts allowing for continuous part transfer in and out of the machine tool. The operator can load a train of carts to run while they attend to other tasks or go "Lights-Out".

**Hefty 150lb (68kg)  
Weight Capacity  
PER PALLET**

Shown on  
5-Axis Mill

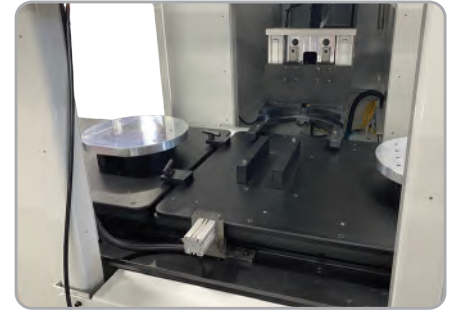

starting at

# \$59,900

Use just **ONE** cart or add **MULTIPLE** carts for an even longer walk-away time

## Shuttle System Includes:

- One (1) cart with two (2) 15" (381mm) dia. pallets.\*
- One (1) cast iron receiver.
- Automatic door retrofit to machining center.
- CE "Light Curtain" package with mirrors and sensors.

*\*Additional carts and pallets available separately. Number of connected carts will vary depending on weight of parts per load.*



# Automatic Pallet-Cart Changer

- Easily load and unload pallets onto carts without obstruction.
- Interlocked pallet carts are mobilized through the shuttle system on casters allowing the shuttle arm to continuously feed pallets into the 5-Axis machining center.
- Once a cart is pushed through the other side, the operator can easily load new pallets and change parts while the spindle is cutting.
- A completed pallet cart can be removed by unlocking the T-pins and rolled to a different location or to the opposite end of the train to keep production going.
- Depending on programming, after the full “pallet cart train” passes through the shuttle, the process repeats sending carts back in the opposite direction.



Individual carts are connected via locking T-pins

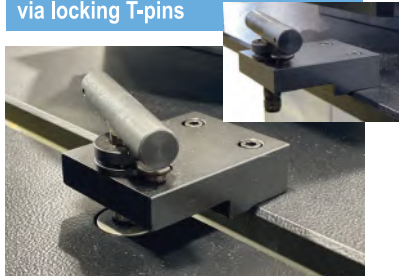

Cast Aluminum Pallet (top)

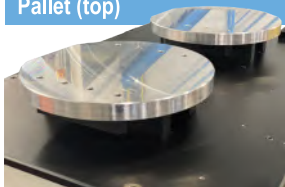

Pallet rails lock pallet to receiver



Hardened and ground pallet bushings with locating pins on cart and receiver assure +/- .0001" (.0025 mm) repeatability.

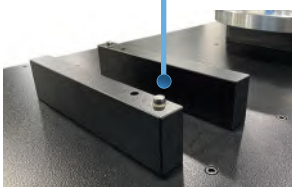

Cast iron receiver mounts directly to the machine table

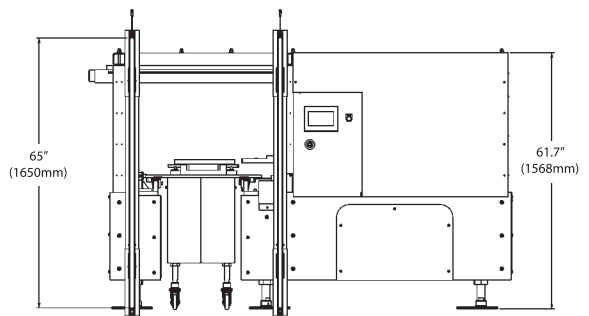
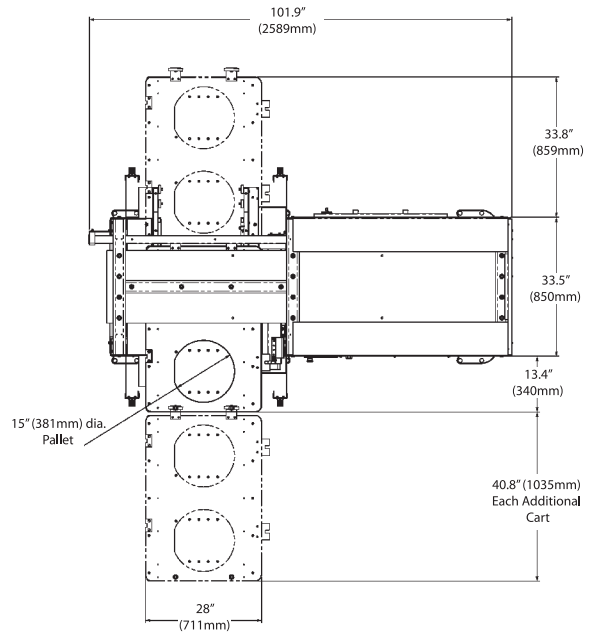
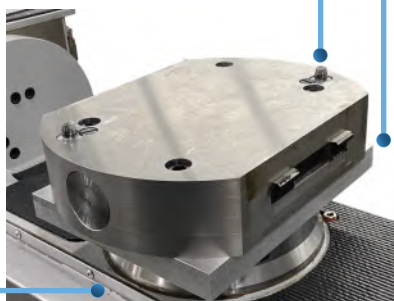

## Specifications:

- 15" (381mm) dia. cast aluminum pallets
- 150 lb (68kg) capacity per pallet
- Cast iron receiver does not require air
- +/- 0.0001" (0.0025 mm) repeatability
- PLC is fully integrated with the machine

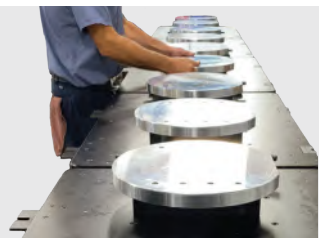

MIDACO pallet systems are designed for machines with stationary guarding. Some machines require options or customization. Patent pending. Contact your sales representative to confirm model and specifications for all applications. Machinery subject to modifications and amendments.



**MIDACO CORPORATION**  
2000 E. Touhy Avenue  
Elk Grove Village, IL 60007 USA  
phone: (847) 593-8420  
fax: (847) 593-8451  
email: midaco@midaco-corp.com



**KEEP THE SPINDLE RUNNING!**  
See how we fit your application  
[www.midaco-corp.com](http://www.midaco-corp.com)

