



MIDACO Vacuum Systems

for CNC Coolant, Oil and Chip Removal



MIDACO CNC Industrial Vacuum Systems are designed to meet the extraction and recovery needs for coolant, oils, and emulsions with efficient filtration of metal chips through a micro-perforated carbon steel basket. This allows for easy disposal or quick reintegration of filtered lubricant and coolant. Decrease CNC machine downtime and reduce maintenance and oil replacement cost due to CNC clean up.



M264VFL Industrial Vacuum for Dry Applications (100L)

Power	2.4 kW 3.3 HP
Full Load Amps	21.4 A*
Max Vacuum	250 mBar
Air Flow Rate	570 m3/h
Voltage	110
Tank Capacity	26.4 gal (100 L)
Vacuum Inlet	2.76" (70 mm)
Sound Level	76 db(A)
Weight	154 lbs (69.85 kg)
Dimensions	26" x 31.5" x 59.65" (660mm x 800mm x 1515mm)

* NEMA L5-30P plug is provided



Accessories Included with M264VFL:

- 1 - flexible hose 124" (3149.6mm) long
- 2 - rubber m/f connectors
- 1 - 18" (457mm) wide squeegee floor tool
- 1 - 15.5" (393.7mm) metal crevice hand tool
- 1 - "S" extension pipe
- 1 - elbow connector
- 1 - Teflon filter
- 2 - reducers
- Wet & Dry upright floor attachment



Description

- 1 - Material enters the chamber through the 2.76" (70mm) suction inlet.
- 2 - Material spins through the "cyclone" and falls into the container.
- 3 - Teflon pocketed filter stops humid and sticky dust generated in the vacuum.
- 4 - Remove dust off the filter INSIDE the canister with the manual "Filter Shaker".
- 5 - Dust and residue fall into the 100 L container for easy disposal.



M264V Industrial Vacuum (100L)

Power	2.4 kW 3.3 HP
Full Load Amps	21.4 A*
Max Vacuum	250 mBar
Air Flow Rate	570 m3/h
Voltage	110
Tank Capacity	26.4 gal (100 L)
Solids Container	13.2 gal (50 L)
Vacuum Inlet	1.97" (50 mm)
Extraction Time	26.4 gal (100 L) / 50 sec
Sound Level	72 db(A)
Weight	198.4 lbs (90 kg)
Dimensions	27.5" x 17.7" x 55" (700mm x 450mm x 1400mm)

* NEMA L5-30P plug is provided

Accessories Included with M264V:

- 1 - flexible hose 124" (3149.6mm) long
- 2 - rubber m/f connectors
- 2 - metal m/m connectors
- 1 - 18" (457mm) wide squeegee floor tool
- 1 - 15.5" (393.7mm) metal crevice hand tool
- 1 - 4.5" (114.3mm) rubber scraper hand tool
- 1 - 2" (50.8mm) dia. rubber round hand tool
- 1 - flat head extension pipe floor tool
- 1 - "S" extension pipe



micro-perforated carbon steel basket with added 150 micron PPL filter for very fine chips



valve handle at base

oil steam filter



Description

- 1 - Vacuum head with 3 single-phase bypass motors.
- 2 - Material enters the "cyclone" and falls into the container.
- 3 - Filter stops the oily steam generated in the vacuum.
- 4 - Liquid is drawn into the 26.4 gal. (100L) container. Safety float stops the vacuum when the container is full.
- 5 - Micro-perforated carbon steel basket separates solids and the liquid. (includes a 150 micron PPL filter for very fine chips)
- 6 - External indicator shows liquid level in the container.

easily move with forklift

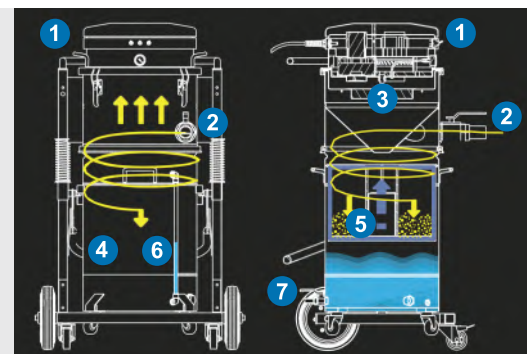

M264VOS Industrial Vacuum with Flow Inversion (100L)

Power	3.4 kW 4.6 HP
Full Load Amps	12.6 A*
Max Vacuum	320 mBar
Air Flow Rate	420 m3/h
Voltage	240V Delta 3-phase
Tank Capacity	26.4 gal (100L)
Solids Container	13.2 gal (50 L)
Vacuum Inlet	1.97" (50 mm)
Extraction Time	26.4 gal (100 L) / 50 sec
Discharge Time	26.4 gal (100 L) / 100 sec
Sound Level	78 dB(A)
Weight	242.5 lbs (110 kg)
Dimensions	33" x 28" x 64" (840mm x 710mm x 1620mm)

* NEMA L15-20P plug is provided

Accessories Included with M264VOS:

- 1 - flexible hose 124" (3149.6mm) long
- 2 - rubber m/f connectors
- 1 - 18" (457mm) wide squeegee floor tool
- 1 - 15.5" (393.7mm) metal flat crevice hand tool
- 1 - "S" extension pipe
- 1 - flat head extension pipe floor tool
- 1 - discharge nozzle



valve handle at top



Description

- 1 & 7 - Side channel blower with reverse flow discharge system.
- 2 - Material enters the "cyclone" and falls into the container.
- 3 - Filter stops the oily steam generated in the vacuum.
- 4 - Liquid is drawn into the 26.4 gal. (100L) container. Safety float stops the vacuum when the container is full.
- 5 - Micro-perforated carbon steel basket separates solids and the liquid. (includes a 150 micron PPL filter for very fine chips)
- 6 - External indicator shows liquid level in the container.

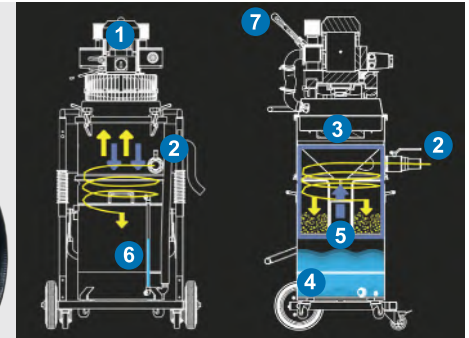

Large Tank Industrial Vacuum with Flow Inversion

Two Sizes: **M740VOS-(280L)** **M1320V-(500L)**

Power	3 kW	3 kW
Full Load Amps	20 Amp*	20 Amp*
Max Vacuum	94 inch H2O	94 inch H2O
Air Flow Rate	345 CFM	345 CFM
Voltage	110	110
Tank Capacity	74 gal (280 L)	132 gal (500 L)
Solids Container	10.57 gal (40 L)	10.57 gal (40 L)
Vacuum Inlet	1.97" (50 mm)	1.97" (50 mm)
Extraction Time	50 gal (189 L) / 100 sec	50 gal (189 L) / 100 sec
Discharge Time	50 gal (189 L) / 100 sec	50 gal (189 L) / 100 sec
Sound Level	72 dB(A)	72 dB(A)
Weight	333 lbs (151 kg)	425 lbs (193 kg)
Dimensions	27.5" x 57" x 55" (700mm x 1450mm x 1400mm)	23.6" x 59.5" x 70" (600mm x 1510mm x 1780mm)

* NEMA L5-30P plug is provided

Accessories Included*:

- 1 - flexible hose 124" (3149.6mm) long
- 2 - rubber m/f connectors
- 1 - 2" (50.8mm) dia. rubber round hand tool



*See the optional **M100OILKIT** for additional accessories (back page)

Description

- 1 - Three (3) powerful by-pass motors activated by a single switch.
- 2 - Pivoting inlet enhanced for effortless maneuverability.
- 3 - Micro-perforated carbon steel basket separates solids and the liquid. (includes a 150 micron PPL filter for very fine chips)
- 4 - Liquid is drawn into the 74 gal./132 gal. (280L/500L) container.
- 5 - Filter stops oily steam generated in the vacuum.
- 6 - A level sensor automatically stops the vacuum upon reaching maximum capacity.
- 7 - Discharge System - externally mounted vacuum pump, maximizing the tank's full capacity and ensuring thorough emptying without any residue.
- 8 - Liquid is discharged through hose and nozzle.





CNC Industrial Vacuum Systems

Optional M1000ILKIT Attachment Kit

- 1 - flexible hose 124" (3149.6mm) long
- 2 - rubber m/f connectors
- 1 - 18" (457mm) wide squeegee floor tool
- 1 - 4.5" (114.3mm) rubber scraper hand tool with metal m/m connector
- 1 - 2" (50.8mm) dia. round rubber hand tool with metal m/m connector
- 1 - 15.5" (393.7mm) metal flat crevice hand tool
- 1 - "S" extension pipe
- 1 - flat head extension pipe floor tool

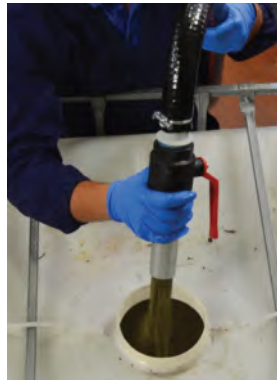

MIDACO CORPORATION
 2000 Touhy Avenue
 Elk Grove Village, IL 60007 USA
 phone: (855) 593-5668
 fax: (847) 593-8451
 email: sales@midaco-corp.com



See how we fit your application
www.midaco-corp.com

