

Model	MX-F401			
Mark	CFV	RFV	KKV	AFV
1 Front casing	CFRETFE			
2 Impeller	CFRETFE			
3 Rear casing	CFRETFE			
4 Magnet capsule	CFRETFE			
5 O-ring*	FKM*			
6 Spindle	High purity Alumina Ceramic		SiC	High purity Alumina Ceramic
7 Bearing	Carbon	PTFE	SiC	High purity Alumina Ceramic
8 Rear thrust	CFRETFE			
9 Mouth ring	PTFE		SiC	PTFE
10 Thrust/Liner ring	High purity Alumina Ceramic		SiC	High purity Alumina Ceramic

* EPDM and AFLAS® O-ring also available.

MX-F401 1.5 HP

- Engineered to meet the most severe operating conditions.
- When fitted with a carbon bearing, the MX will allow for brief periods of dry running.
- The MX Series is the first resin magnet pump that uses a *Split Volute Pump Casing* that forms a vortex chamber.
- Self-radiating structure (patent pending) – Heat dispersion holes force the liquid to circulate around the spindle and bearing .

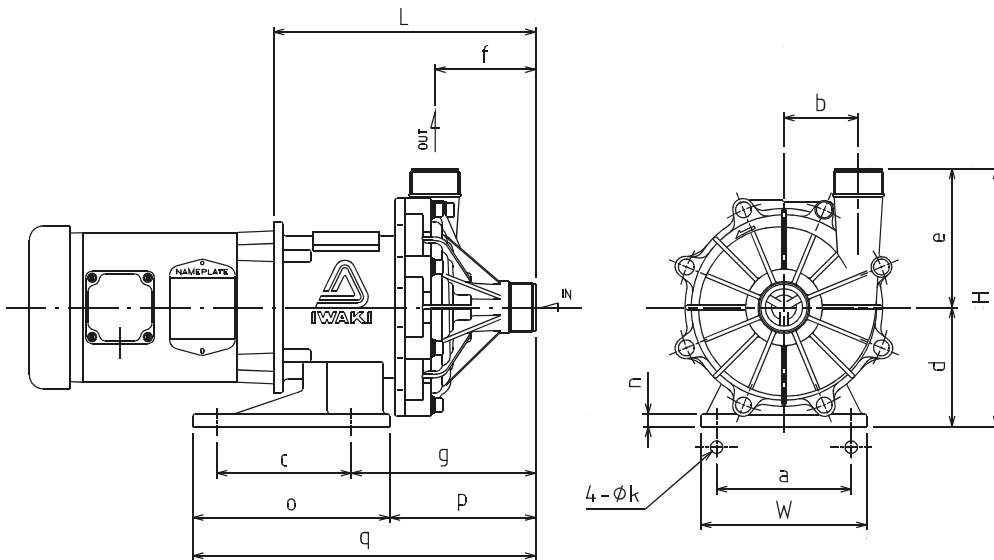

Dimensions (in inches)

a	b	c	d	e	f	g	k	n	o	p	q	W	H	L
5.12	2.83	5.12	4.53	5.28	3.82	7.01	.47	.47	7.48	5.55	13.03	6.30	9.81	9.96

Specifications

Suction x Discharge	Maximum Discharge Pressure	Maximum Flow	Specific Gravity	Weight (less motor)
1.5" x 1.5"	V = 68 ft. X = 50 ft.	V = 86 gpm X = 75 gpm	1.2	22.5 lbs

