

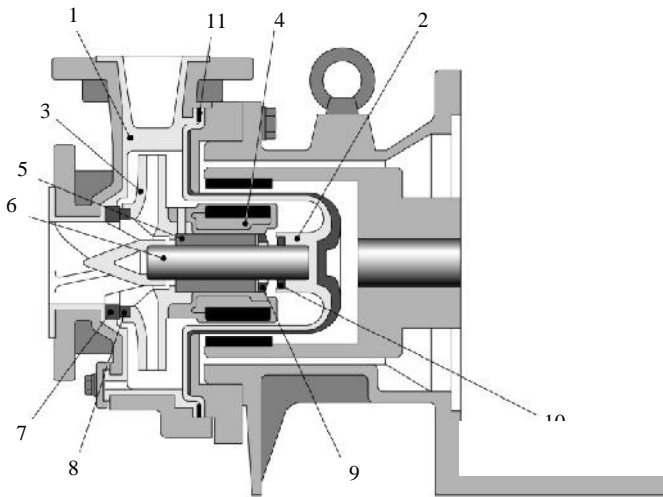

MDM-2526 7.5/10HP



- ❑ Non-contact Bearing System allows dry run operation (CF models only)
- ❑ Simple, rugged design
- ❑ Corrosion resistant ETFE & PFA internals
- ❑ Spline/pinned impeller design (pat. pending) provides positive locking of impeller/inner magnet while still allowing for individual replacement of each part
- ❑ PFA version temperatures to 302°F

Part	Material		
	ECF	EKK	PKK
1 Front casing	CFRETFE (carbon fiber reinforced ETFE)		PFA
2 Containment shell			
3 Impeller			
4 Inner magnet assy			
5 Bearing	High density carbon	SiC	
6 Shaft	High purity alumina ceramic		
7 Front outboard thrust collar	PTFE		
8 Front inboard thrust collar	High purity alumina ceramic		
9 Rear inboard thrust collar	PTFE (filler charged)		
10 Rear outboard thrust collar	PTFE		
11 Gasket	PTFE		

Dimensions (inches) and Specifications

Note: Will vary by motor manufacturer

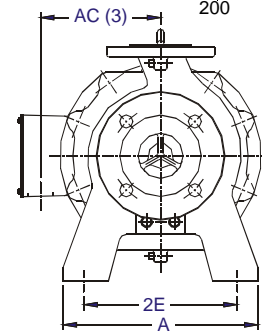
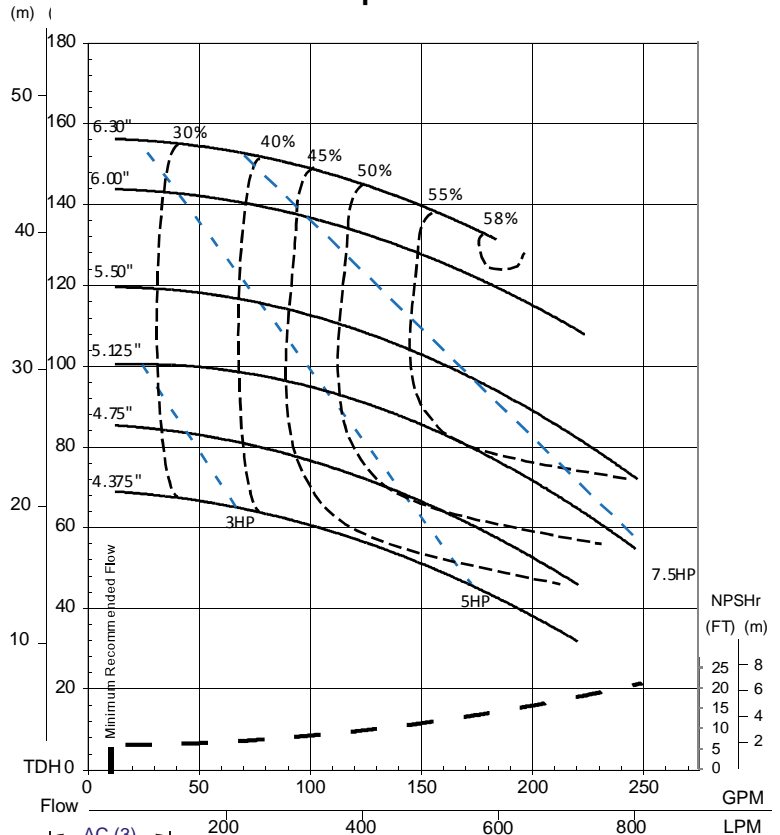
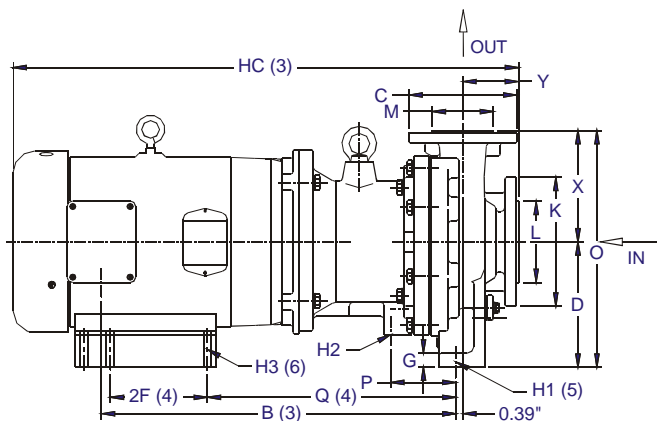

*Pump end only. Does not include motor.

A	AC(3)	B(3)	D	2E1	2F(4)	G	H1(5)	H2	H3(4)	HC(3)	O	P	Q(4)	X	Y
11.02	6.79	20.07	7.09	8.66	5.50/ 7.00	0.79	0.55	3/8-16UNC	0.41	28.62	13.39	3.70	14.07	6.30	3.15
HP/Frame		Connection Sizes		Min Flow/Max Head		Standard Capacity		Max Capacity		Pump Weight*		K	L	C	M
7.5/213TC & 10/215TC		2.5 x 2		13/155		180		260		132		7.28	4.61	6.10	3.46