



1K Series Stainless Steel Submersible Pumps

Models

1K100-1K505

FEATURES

- 304SSL construction offers corrosion resistance and increases operating life over typical cast iron models.
- Unique bulge formed components eliminates harsh radius and welds and provides greater efficiency and durability.
- Lubricated double mechanical seal offers dependable performance with a variety of liquids.
- Air filled, continuous-duty motors for reliable, long term operation.
- Single phase motor features permanent split capacitor and thermal protection with automatic reset for added protection and extend motor life.
- Versatile, reliable operation whether fully or partially submerged.
- Multiple sizes from 1/3 to 1-1/2 hp offers application flexibility.
- Sealed float switch for automatic operation.

Quality Materials

- Casing is 304SSL for durability over traditional cast iron.
- Semi-open impeller is 304SSL for long life, durability and economy. (1K100 and 1K102 feature RTP-Noryl.)
- Shaft is 304SSL for dependable, long life.
- Motor frame is 304SSL for dependability.
- Fasteners are all 304SS for durability.
- Shaft Seals are special blend NBR and FPM for compatibility and long life.
- Sealed Bearings for longer life.

SPECIFICATIONS

	U.S. Measure
Flow Rangeup to 88 gpm
Pressure Range up to 24 psi
 up to 55 Ft. Head
RPM3450 RPM
Discharge Fitting	1/3 HP 1-1/4 NPT
	1/2-1-1/2 HP 1-1/2 NPT
Motor Phase	Single Class F 115V
	Three Class F 230V
	Three Class F 460V
Cycle 60 Hz
Cable Length	1 PH[Gauge AWG 16, UL/CSA 3-Prong] 20 Ft.
	3 PH [Gauge AWG 16, UL/CSA] 20 Ft.
Float Operation Manual or Automatic
Maximum Starts/Hour20
Maximum Temperature
	(Continuous) 122°F
	(Intermittent)..... 140°F
Maximum Solids Diameter 3/8"
Weight (see charts) 11-31 lbs.
Dimensions (see charts)	
	Length10.25-17.18"
	Diameter6.37-8.25"

CAPACITY IN GALLONS PER MINUTE (GPM)											
MODEL	FEET OF HEAD										
	5	10	15	20	25	30	35	40	45	50	55
1K100-103	45	39	31	21	5						
1K201-205		73	67	60	51	40	27	9			
1K301-305			74	67	58	49	39	28	16		
1K404-405				82	75	65	55	42	27		
1K504-505				88	81	74	65	54	43	25	

GENERAL SAFETY AND OPERATION

1. Use with the proper electrical receptacle. On single phase models cord is supplied with a grounding type, 3-prong plug. On a three phase models, no 3-prong plug is supplied.
NOTE: DO NOT USE GROUNDING ADAPTER.
2. Do not use if outer covering of cord becomes excessively cut or worn.
3. Each pump comes with a built-in handle for lifting. For added convenience, the 899045 25 ft. marine rope can be attached to the handle.

WARNING

Do not lift with power cord. This can cause damage to the connection and result in shock or serious injury.

4. Continued cycling on and off is an indication the motor is in overload. Make certain the pump is level and adequately submersed in liquid.

NOTE: CONTINUED OPERATION WITH EXCESSIVE CYCLING WILL OVERHEAT AND BURN OUT MOTOR.

5. All automatic models come with a float switch to shut-off unit when liquid level drops below safe operation. For field retro-fit, the 899080 [115V] float switch can be added to automate the manual units.

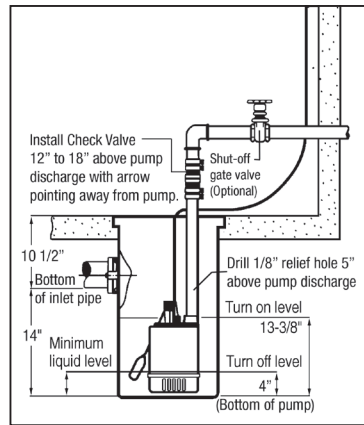

1K SERIES PERFORMANCE RANGES

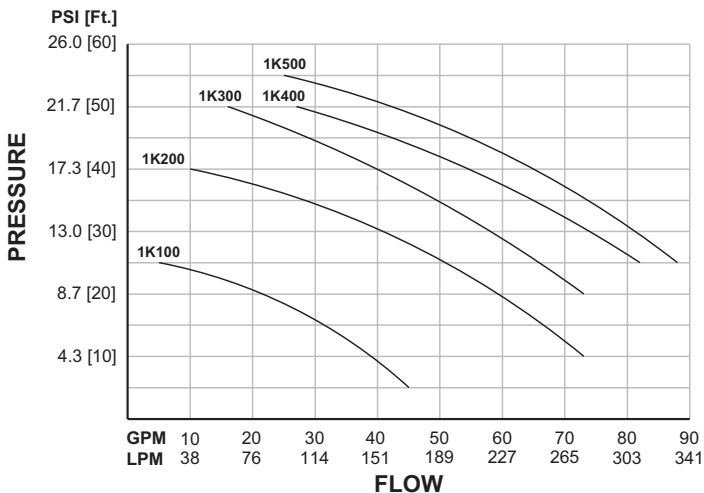

TROUBLESHOOTING

PUMP WON'T START

- Blown fuse or tripped circuit
- Low voltage line
- Defective motor
- Impeller clogged
- Check power supply.
- Check power supply.
- Overheated and burned out unit must be replaced.
- Check for proper particle size. Maximum 3/8" and 2% concentrate and raise from bottom of pit.
- Reposition pump in liquid with minimum 2-3/8" liquid.

- Not primed

PUMP CYCLES ON AND OFF

- Insufficient liquid
- Pump run dry
- Liquid temperature to high
- Reposition pump in pit or remove if liquid is too low.
- Keep liquid within pump limits. Remove if liquid is low.
- Keep liquid within pump limits.

PUMP OPERATES BUT DELIVERS LITTLE FLOW

- Impeller clogged
- Low voltage
- Worn seals
- Check liquid and particle size. Flush impeller area.
- Check power supply.
- Replace pump unit.

AUTOMATIC MODELS

Model	HP	Phase	Volts	Amps	Pump-Motor Dimensions (in.)					Wt. (lbs.)
					A	B	C	D	E (NPT)	
1K100	1/3	1*	115	4.0	10.25	8.06	6.37	2.26	1.25	11
1K101	1/3	1*	115	4.0	10.25	8.06	6.37	2.26	1.25	11
1K201	1/2	1*	115	9.0	17.18	13.62	8.25	2.62	1.50	27
1K301	3/4	1*	115	12.2	17.18	13.62	8.25	2.62	1.50	27

MANUAL MODELS

Model	HP	Phase	Volts	Amps	Pump-Motor Dimensions (in.)					Wt. (lbs.)
					A	B	C	D	E (NPT)	
1K102	1/3	1*	115	4.0	10.25	8.66	6.37	2.37	1.25	11
1K103	1/3	1*	115	4.0	10.25	8.66	6.37	2.37	1.25	11
1K203	1/2	1*	115	9.0	17.18	13.62	8.25	2.37	1.50	27
1K204	1/2	3	230	3.1	13.87	12.37	8.25	2.37	1.50	27
1K205	1/2	3	460	1.55	13.87	12.37	8.25	2.37	1.50	27
1K303	3/4	1*	115	12.2	17.18	13.37	8.25	2.37	1.50	28
1K304	3/4	3	230	3.8	13.87	12.37	8.25	2.37	1.50	28
1K305	3/4	3	460	2.0	13.87	12.37	8.25	2.37	1.50	28
1K404	1	3	230	4.8	14.81	13.37	8.25	2.37	1.50	31
1K405	1	3	460	2.5	14.81	13.37	8.25	2.37	1.50	31
1K504	1-1/2	3	230	5.3	14.81	13.37	8.25	2.37	1.50	31
1K505	1-1/2	3	460	2.7	14.81	13.37	8.25	2.37	1.50	31

*Only single phase has motor over-load and auto-reset.

DIMENSIONAL

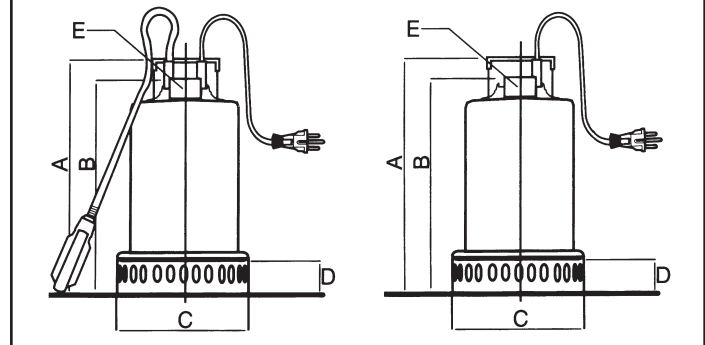

WARRANTY

This pump is warranted for one year from date of purchase.
Improper installation and use will void the warranty.
Tampering with the power cord, impeller or seals will void the warranty.



CAT PUMPS

1681 - 94TH LANE N.E. MINNEAPOLIS, MN 55449-4324
PHONE (763) 780-5440 — FAX (763) 780-2958
e-mail: techsupport@catpumps.com
www.catpumps.com